

**GENERAL NOTES:**

1. THIS DRAWING IS TO BE READ IN CONJUNCTION WITH ALL RELEVANT ARCHITECTS AND ENGINEERS DRAWINGS AND SPECIFICATIONS.
2. DO NOT SCALE THIS DRAWING. ANY AMBIGUITIES, OMISSIONS AND ERRORS ON DRAWINGS SHALL BE BROUGHT TO THE ENGINEERS ATTENTION IMMEDIATELY. ALL DIMENSIONS MUST BE CHECKED / VERIFIED ON SITE.
3. ALL DIMENSIONS ARE IN METRES UNLESS OTHERWISE SPECIFIED.
4. FOR GENERAL NOTES REFER TO DRAWING.

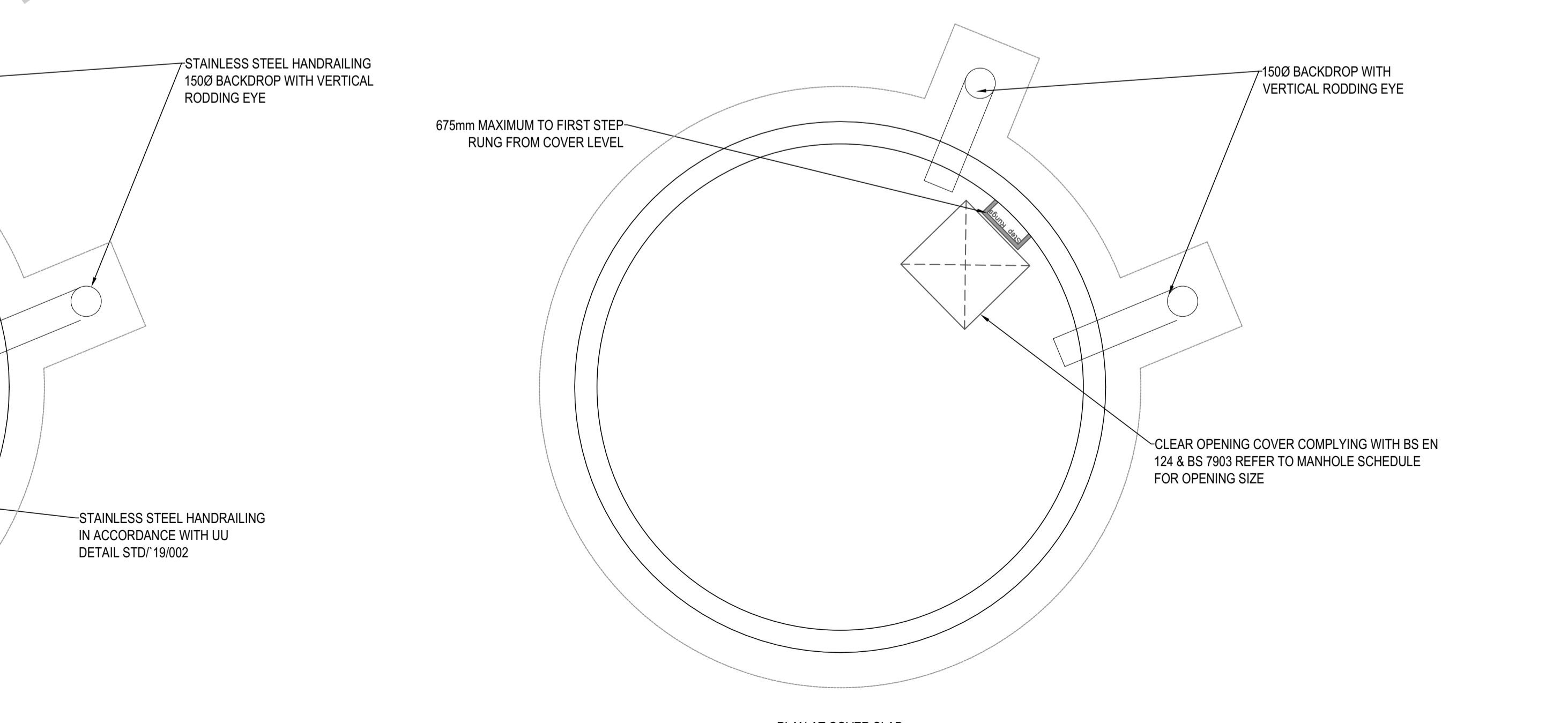
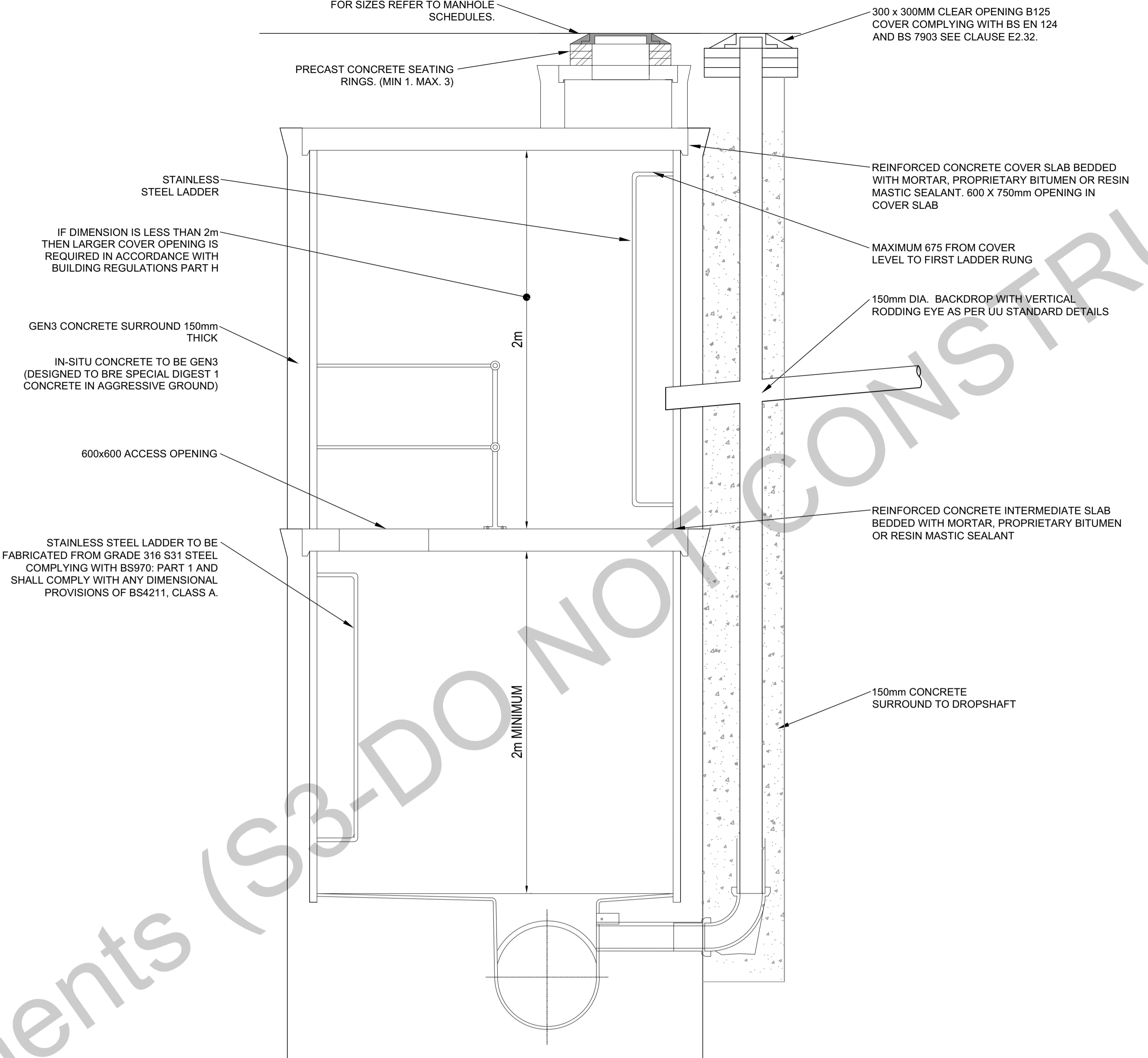
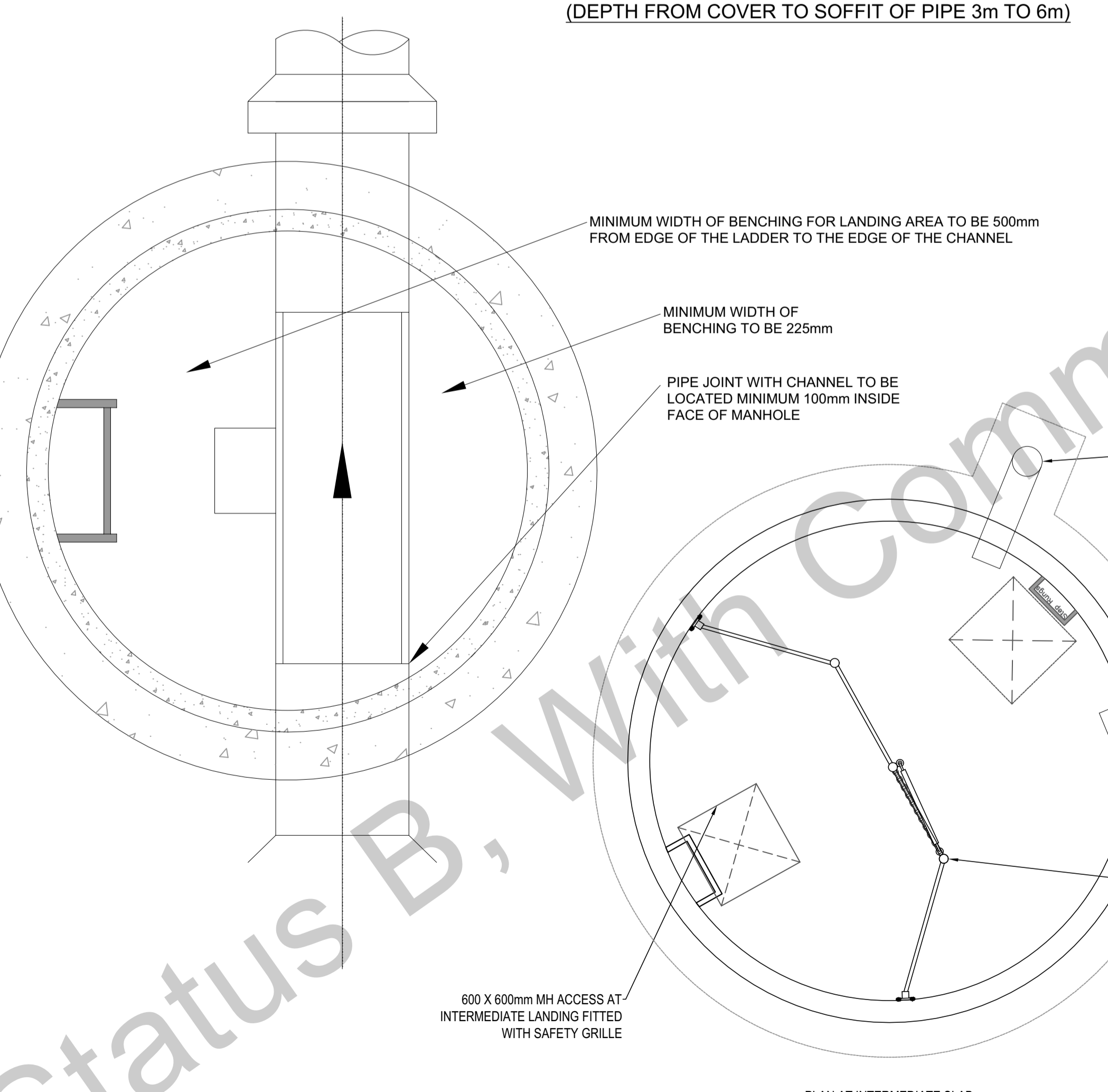
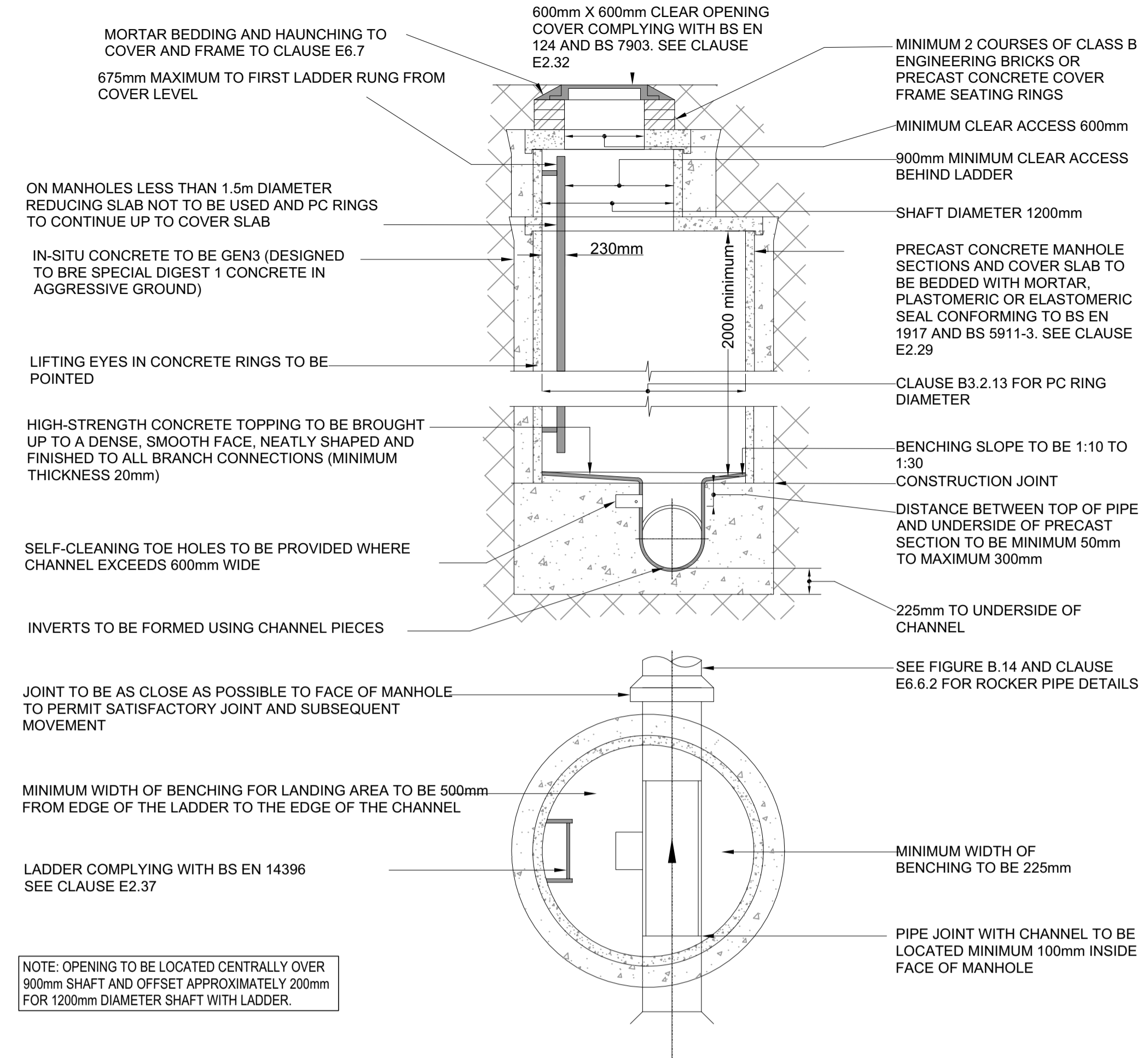

P01	STAGE 4 ISSUE	11.08.22	LK	HS
Rev:	Description:	Date:	By:	Chkd:

**Curtins**  
 Merchant Exchange, 17-19 Whitworth Street West, Manchester, M1 5WG  
 0161 236 2364  
 manchester@curtins.com  
 www.curtins.com

Status: **STAGE 4** **S3**

Project: **MSCP ENABLING WORKS**

Dig Title: **TYPICAL DRAINAGE DETAILS SHEET 1 OF 2**

Drawn By	Designed By	Checked By
LK	LK	HS
077416	Date	Scales @ A1
	10.08.22	NTS

Project No - Originator - Function - Spatial - Form - Discipline - Number	Revision
20200 - CUR - NM110-EX - DR - D - 7509	P01

Status B, With Comments (S3-DO NOT CONSTRUCT)



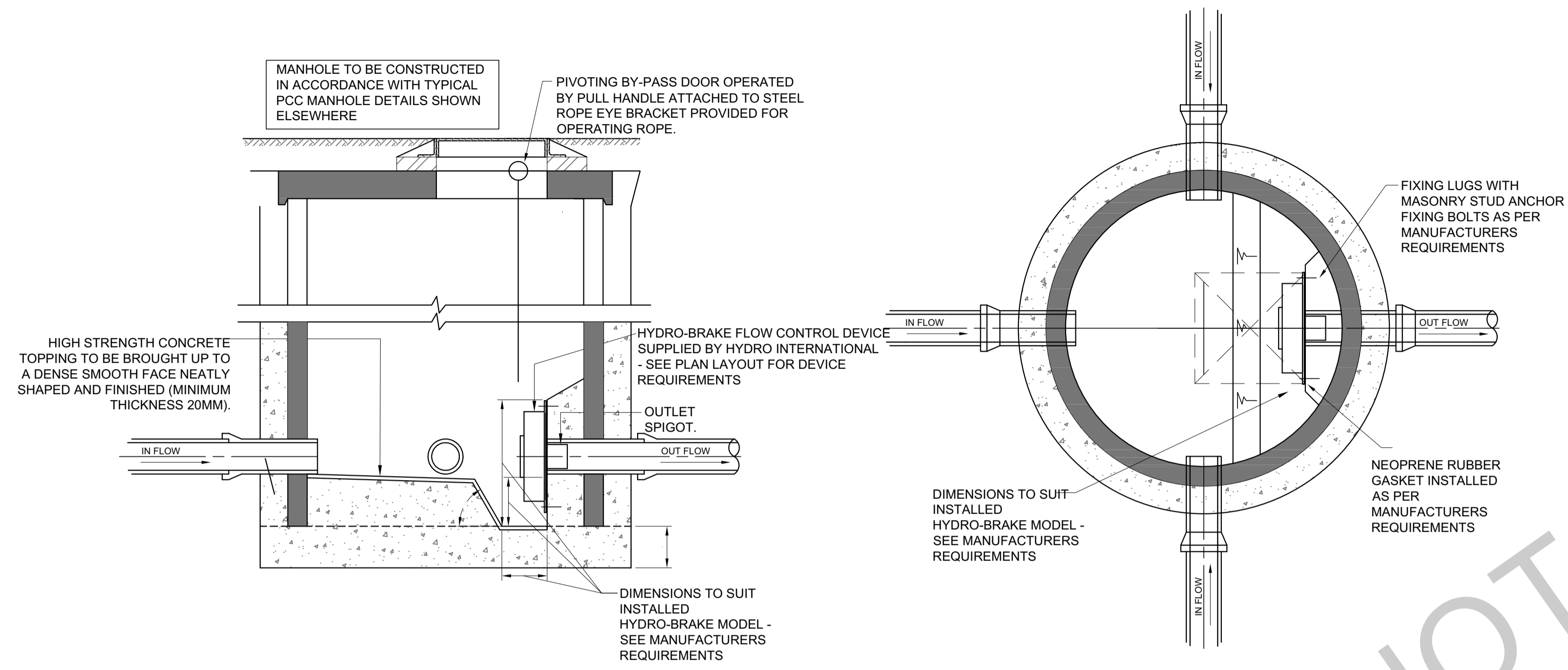

TYPICAL FLOW CONTROL MANHOLE (HYDRO-BRAKE)

GENERAL NOTES:

1. THIS DRAWING IS TO BE READ IN CONJUNCTION WITH ALL RELEVANT ARCHITECTS AND ENGINEERS DRAWINGS AND SPECIFICATIONS.
2. DO NOT SCALE THIS DRAWING. ANY AMBIGUITIES, OMISSIONS AND ERRORS ON DRAWINGS SHALL BE BROUGHT TO THE ENGINEERS ATTENTION IMMEDIATELY. ALL DIMENSIONS MUST BE CHECKED / VERIFIED ON SITE.
3. ALL DIMENSIONS ARE IN METRES UNLESS OTHERWISE.
4. FOR GENERAL NOTES REFER TO DRAWING.

**Technical Specification**

Control Point	Head (m)	Flow (l/s)
Primary Design	2.500	10.500
Flush-Flo™	0.555	9.162
Kick-Flo®	1.138	7.245
Mean Flow		8.491

Hydro-Brake® Optimum Flow Control including:

- 5 mm grade 304L stainless steel
- Integral stainless steel pivoting by-pass door allowing clear line of sight through to outlet, c/w stainless steel operating rope
- Beed blasted finish to maximise corrosion resistance
- Stainless steel fixings
- Rubber gasket to seal outlet
- Indicative Weight: 484 kg

hydro-int.com/patents

**IMPORTANT:** LIMIT OF HYDRO INTERNATIONAL SUPPLY. THE DEVICE WILL BE HANDED TO SUIT SITE CONDITIONS FOR SITE SPECIFIC DETAILS AND MINIMUM CHAMBER SIZE REFER TO HYDRO INTERNATIONAL. ALL CIVIL AND INSTALLATION WORK BY OTHERS. \*WHERE SUPPLIED. HYDRO-BRAKE® FLOW CONTROL & HYDRO-BRAKE® OPTIMUM FLOW CONTROL ARE REGISTERED TRADEMARKS FOR FLOW CONTROL DEVICES DESIGNED AND MANUFACTURED EXCLUSIVELY BY HYDRO INTERNATIONAL.

**THIS DESIGN LAYOUT IS FOR ILLUSTRATIVE PURPOSES ONLY. NOT TO SCALE.**

**DESIGN ADVICE**  
The head/flow characteristics of this SHE-0127-1050-2500-1050 Hydro-Brake® Optimum Flow Control are unique. Dynamic hydraulic modelling evaluates the full head/flow characteristic curve. The use of any other flow control will invalidate any design based on this data and could constitute a flood risk.

**Hydro International**

DATE: 10/08/2022 20:11  
SITE: SHE-0127-1050-2500-1050  
DESIGNER: LLOYD KEEGAN  
REF: Hydro-Brake® Optimum

© 2022 Hydro International Ltd, Shearwater House, Cleveon Hill Estate, Victoria Road, Cleveon, BS21 7RD. Tel: 01275 878371 Fax: 01275 874879 Web: www.hydro-int.com Email: enquiries@hydro-int.com lloydkeegan89@gmail.com

**Technical Specification**

Control Point	Head (m)	Flow (l/s)
Primary Design	2.500	10.500
Flush-Flo™	0.555	9.162
Kick-Flo®	1.138	7.245
Mean Flow		8.491

hydro-int.com/patents

Head (m)	Flow (l/s)
0.000	0.000
0.086	3.657
0.172	7.423
0.259	8.316
0.345	8.809
0.431	9.059
0.517	9.154
0.603	9.150
0.690	9.080
0.776	8.954
0.862	8.762
0.948	8.473
1.034	8.041
1.121	7.415
1.207	7.447
1.293	7.691
1.379	7.927
1.466	8.155
1.552	8.377
1.638	8.592
1.724	8.802
1.810	9.006
1.897	9.205
1.983	9.400
2.069	9.590
2.155	9.777
2.241	9.959
2.328	10.139
2.414	10.314
2.500	10.487

**DESIGN ADVICE**  
The head/flow characteristics of this SHE-0127-1050-2500-1050 Hydro-Brake Optimum® Flow Control are unique. Dynamic hydraulic modelling evaluates the full head/flow characteristic curve. The use of any other flow control will invalidate any design based on this data and could constitute a flood risk.

**Hydro International**

DATE: 10/08/2022 20:11  
SITE: SHE-0127-1050-2500-1050  
DESIGNER: LLOYD KEEGAN  
REF: Hydro-Brake Optimum®

© 2016 Hydro International, Shearwater House, Cleveon Hill Estate, Victoria Road, Cleveon, BS21 7RD. Tel: 01275 878371 Fax: 01275 874879 Web: www.hydro-int.com Email: design@hydro-int.com

P01	STAGE 4 ISSUE	11.08.22	LK	HS	
Rev:	Description:	Date:	By:	Chkd:	
<p>Merchant Exchange, 17-19 Whitworth Street West, Manchester, M1 5WG 0161 236 2384 manchester@curtins.com www.curtins.com</p> <p>Civil &amp; Structural • Transport Planning • Environmental • Infrastructure • Geotechnical • Conservation &amp; Heritage • Principal Designer Birmingham • Bristol • Cambridge • Cardiff • Douglas • Dublin • Edinburgh • Glasgow • Kenton • Leeds • Liverpool • London • Manchester • Nottingham</p>					
Status:	STAGE 4		S3		
Project:	MSCP ENABLING WORKS				
Dwg Title:	TYPICAL DRAINAGE DETAILS SHEET 2 OF 2				
Drawn By:	LK	Designed By:	LK	Checked By:	HS
077416	Date:	10.08.22	Scale:	@ A1 NTS	
Project No - Originator - Function - Spatial - Form - Discipline - Number				Revision	
20200 - CUR - NM110-EX - DR - D - 7510				P01	

Status B, With Comments

U:\m\02\Projects\07701 - 07800\077416 - North Manchester General Hospital\04-Production\A4-Model-Drawing\02\DC\01\MSCP - Remedial Works



- THIS DRAWING IS TO BE READ IN CONJUNCTION WITH ALL RELEVANT ARCHITECTS AND ENGINEERS DRAWINGS AND SPECIFICATIONS.
- DO NOT SCALE THIS DRAWING. ANY AMBIGUITIES, OMISSIONS AND ERRORS ON DRAWINGS SHALL BE BROUGHT TO THE ENGINEERS ATTENTION IMMEDIATELY. ALL DIMENSIONS MUST BE CHECKED / VERIFIED ON SITE.
- ALL DIMENSIONS ARE IN MILLIMETRES UNLESS NOTED OTHERWISE.
- SULPHATE RESISTANT CEMENT (C20-DC2) AND PRECAST CONCRETE PRODUCTS MUST BE USED OR A LABORATORY REPORT PROVIDED TO PROVE THAT SUCH PRECAUTIONS ARE NOT REQUIRED.

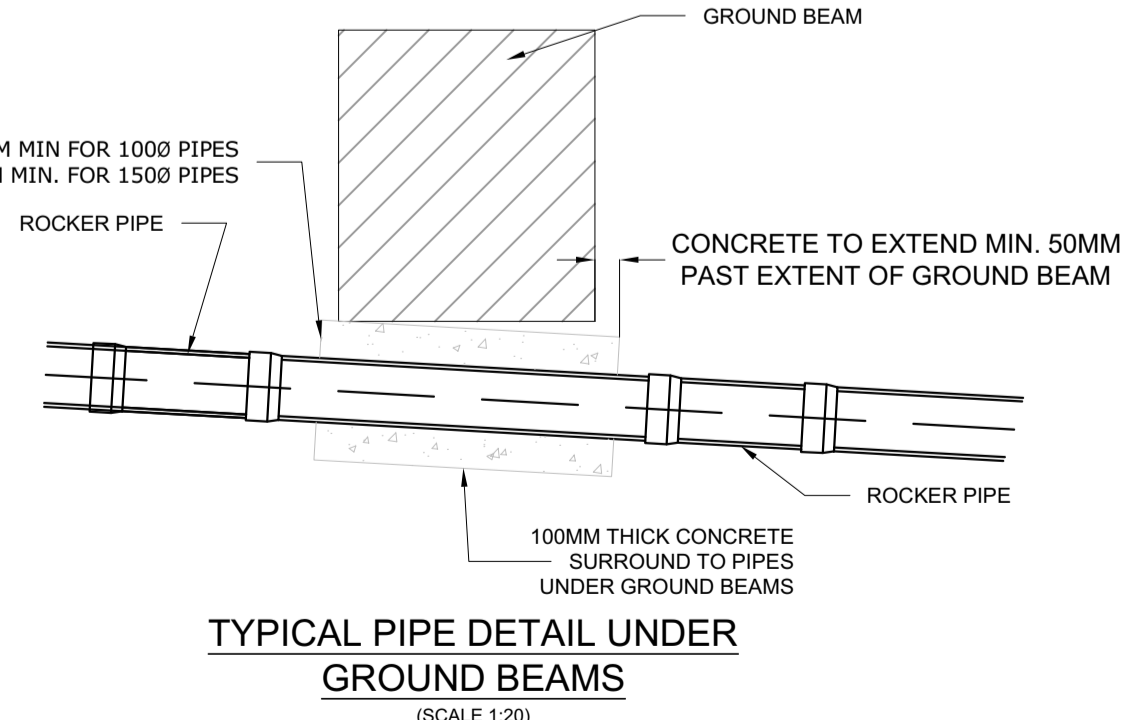
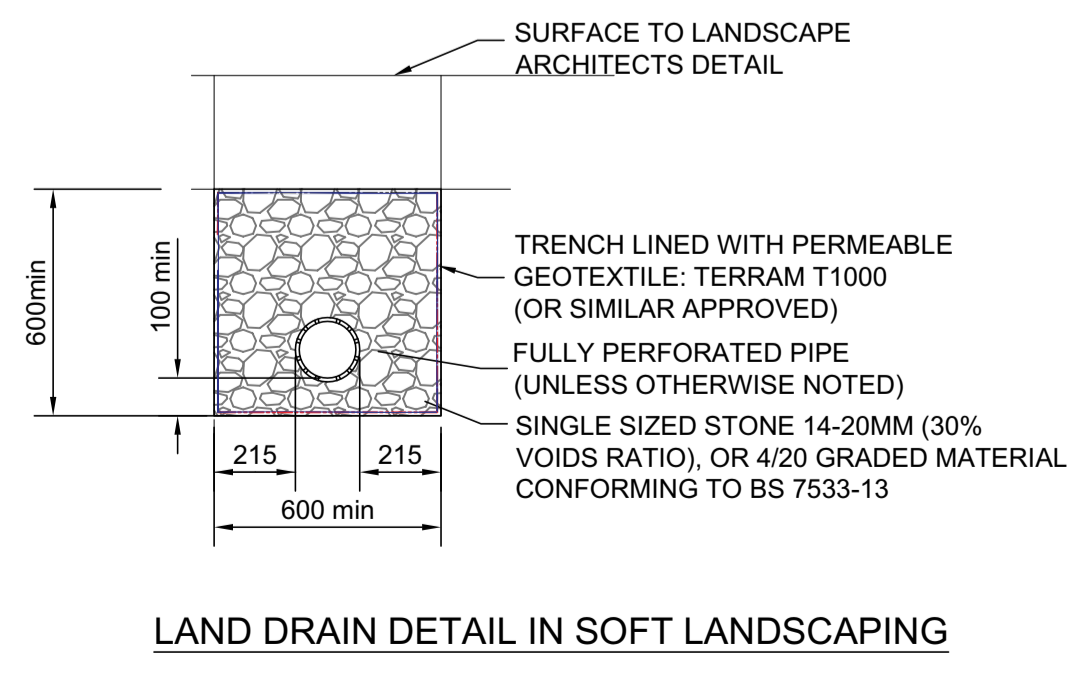
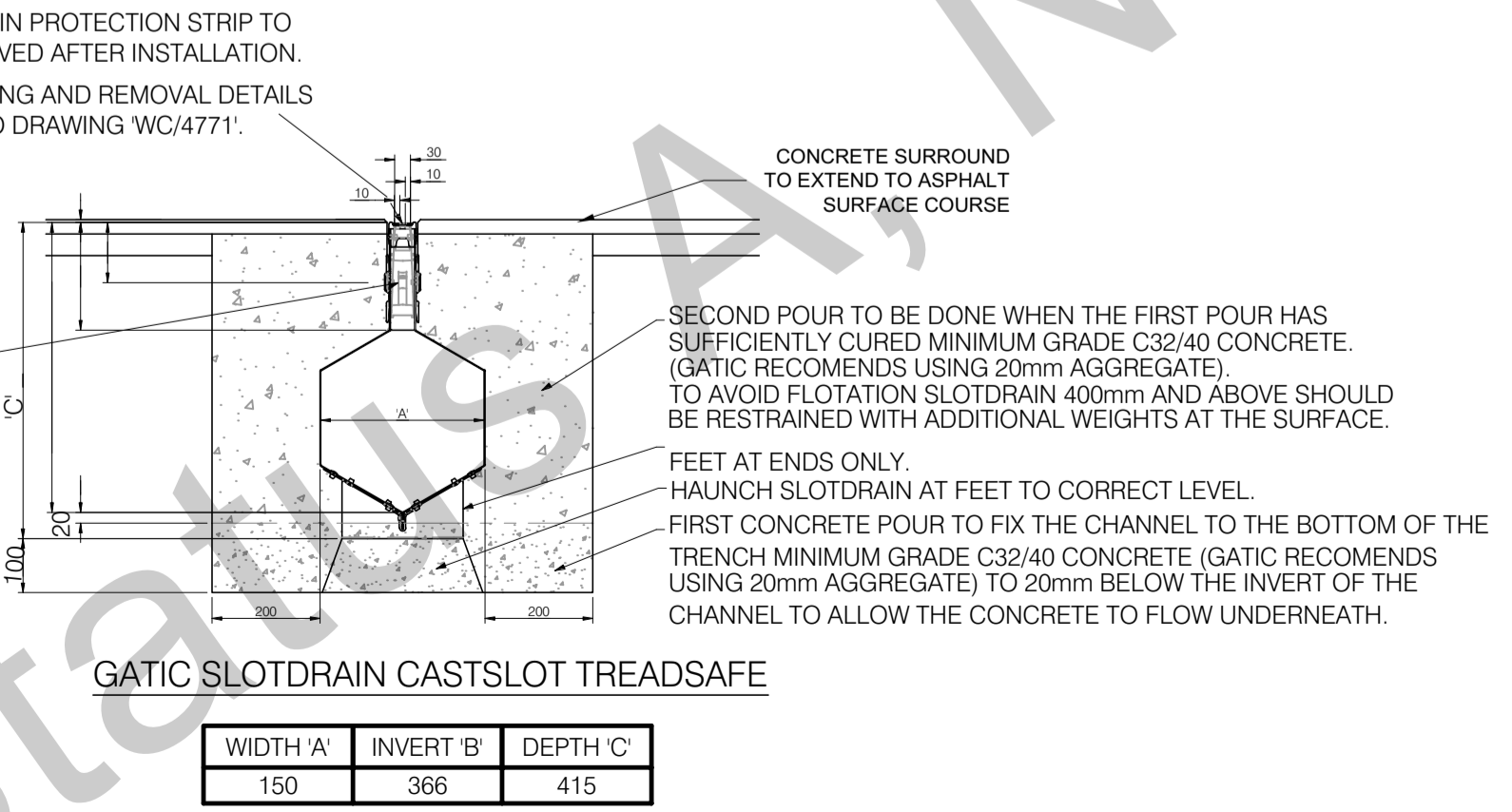
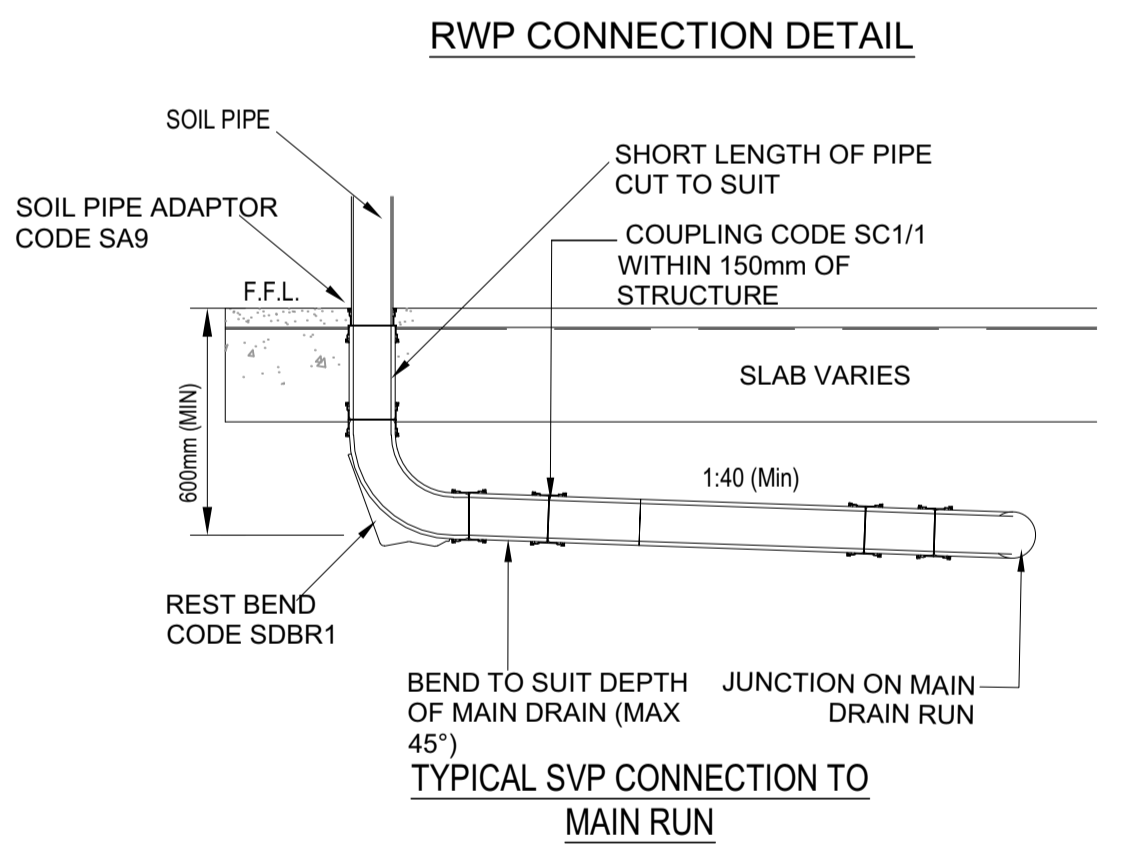
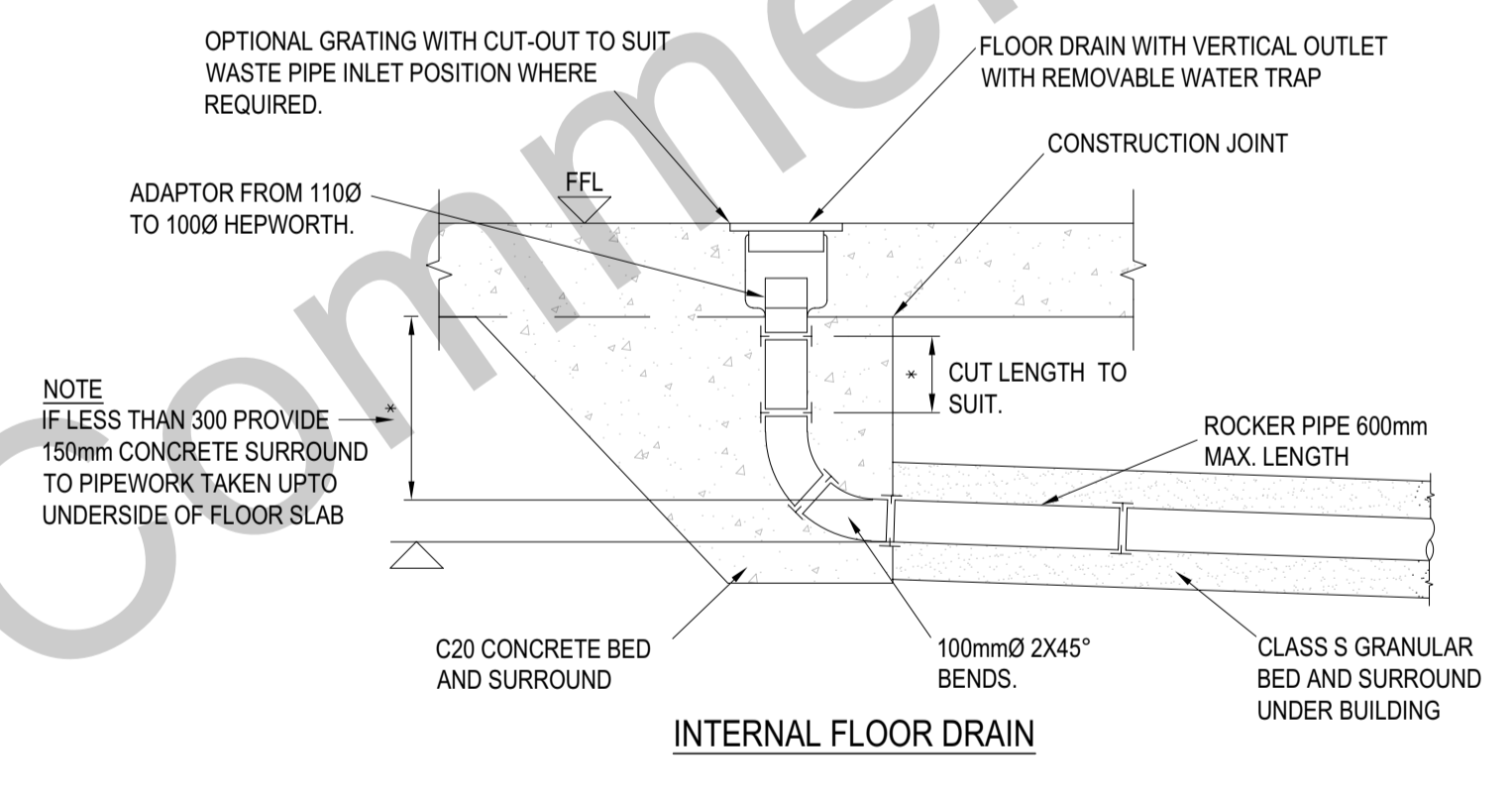
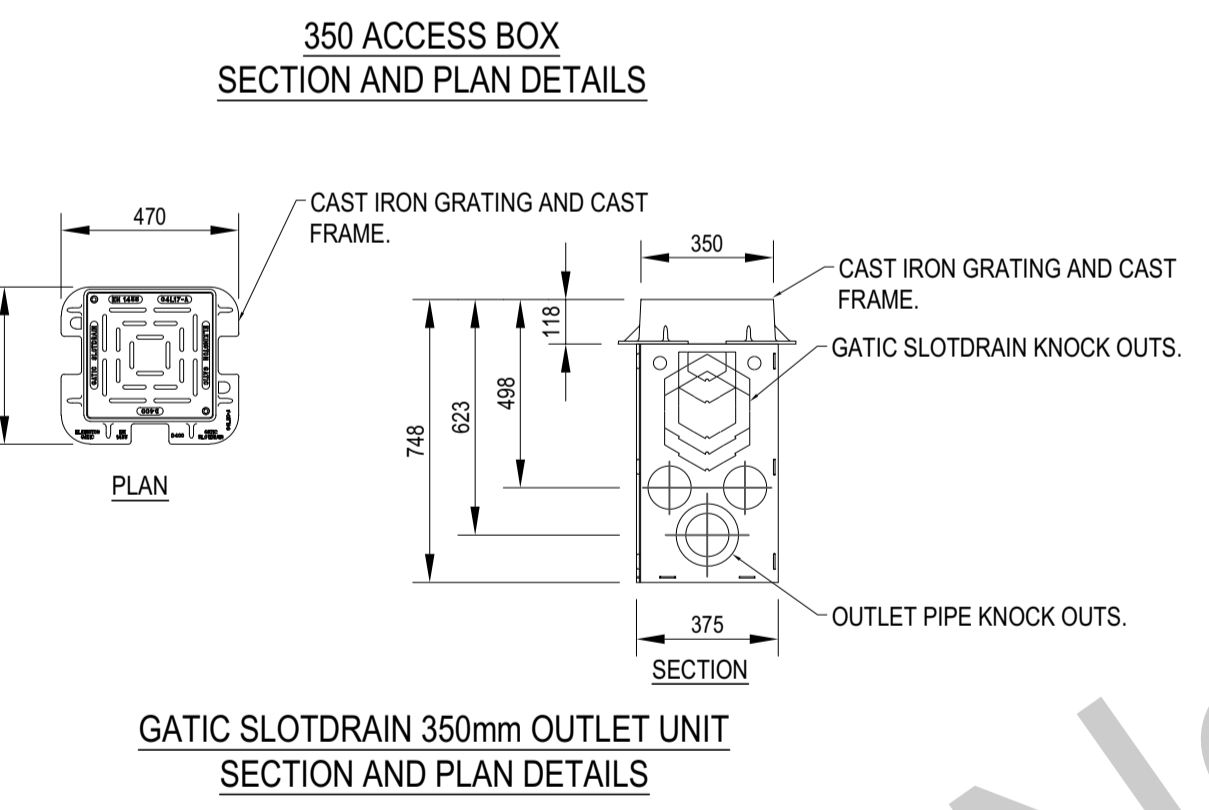
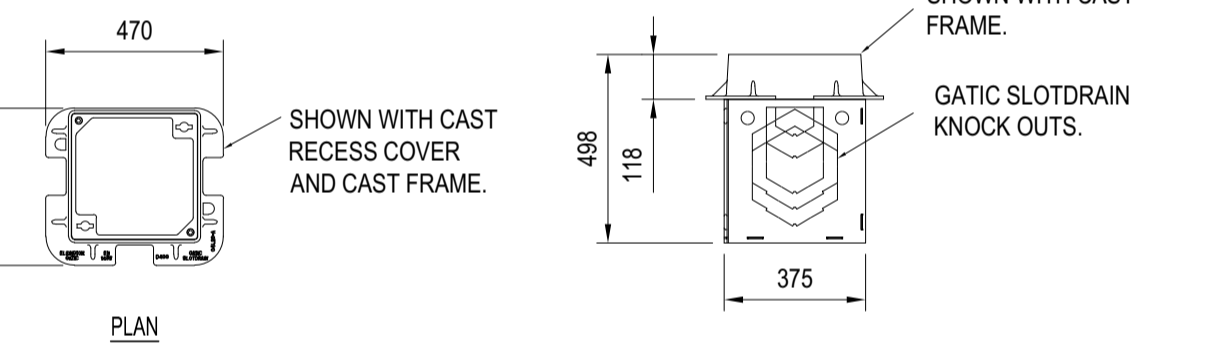
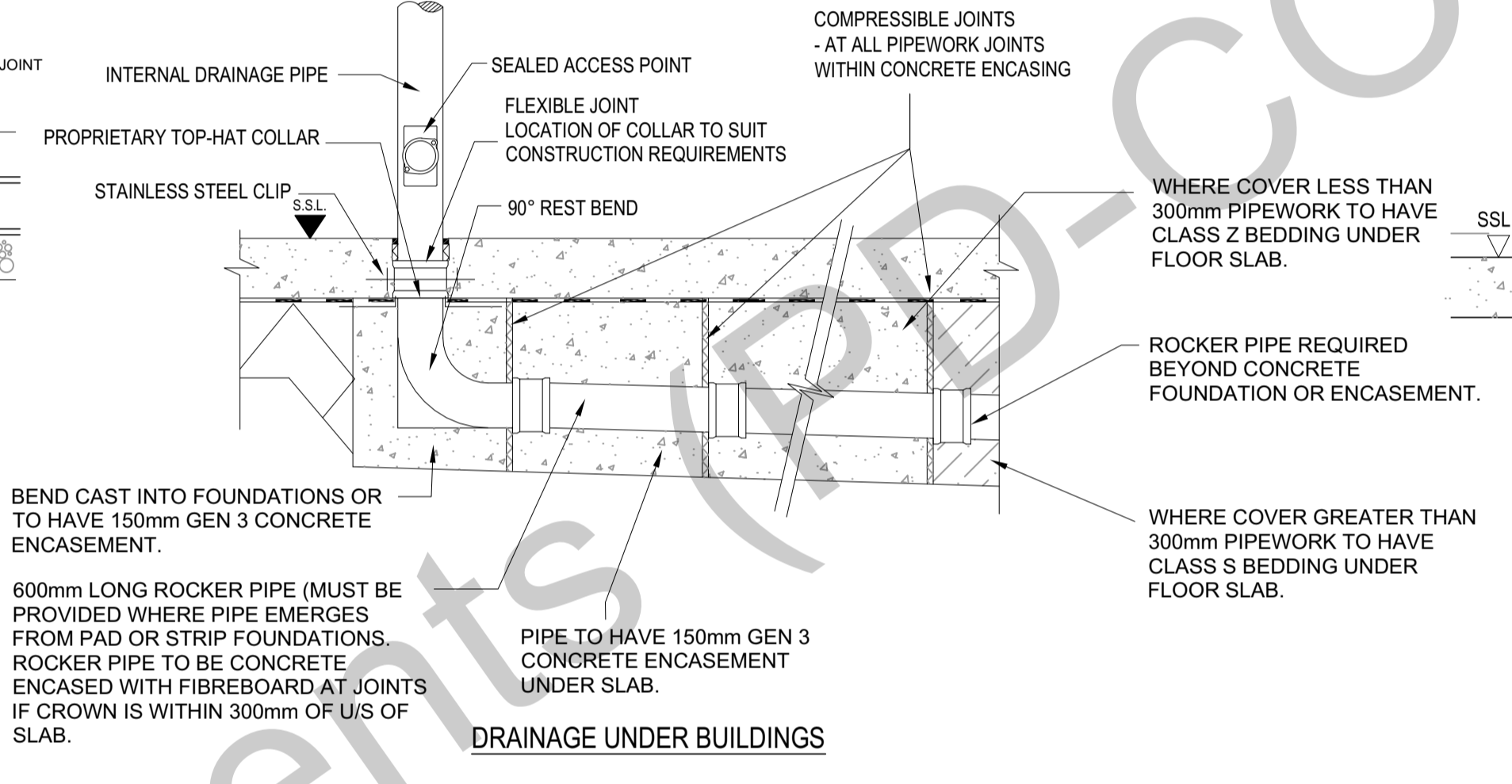
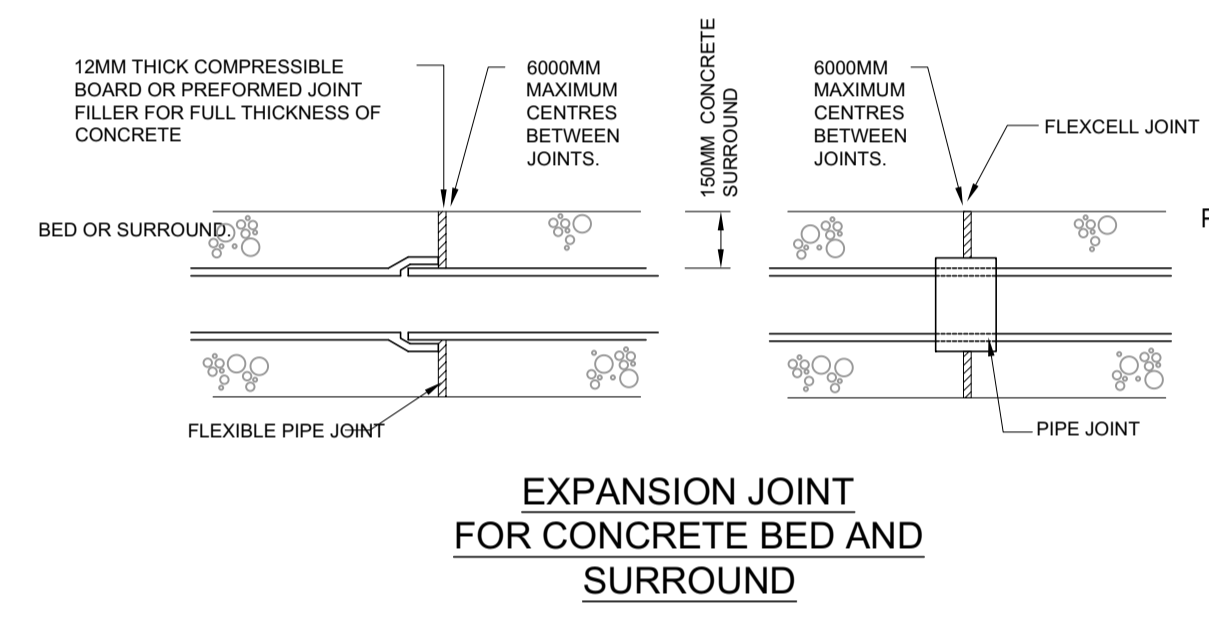
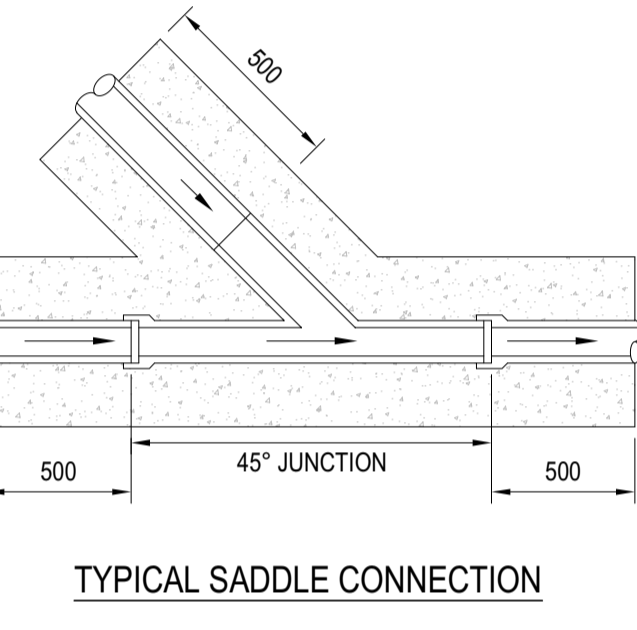
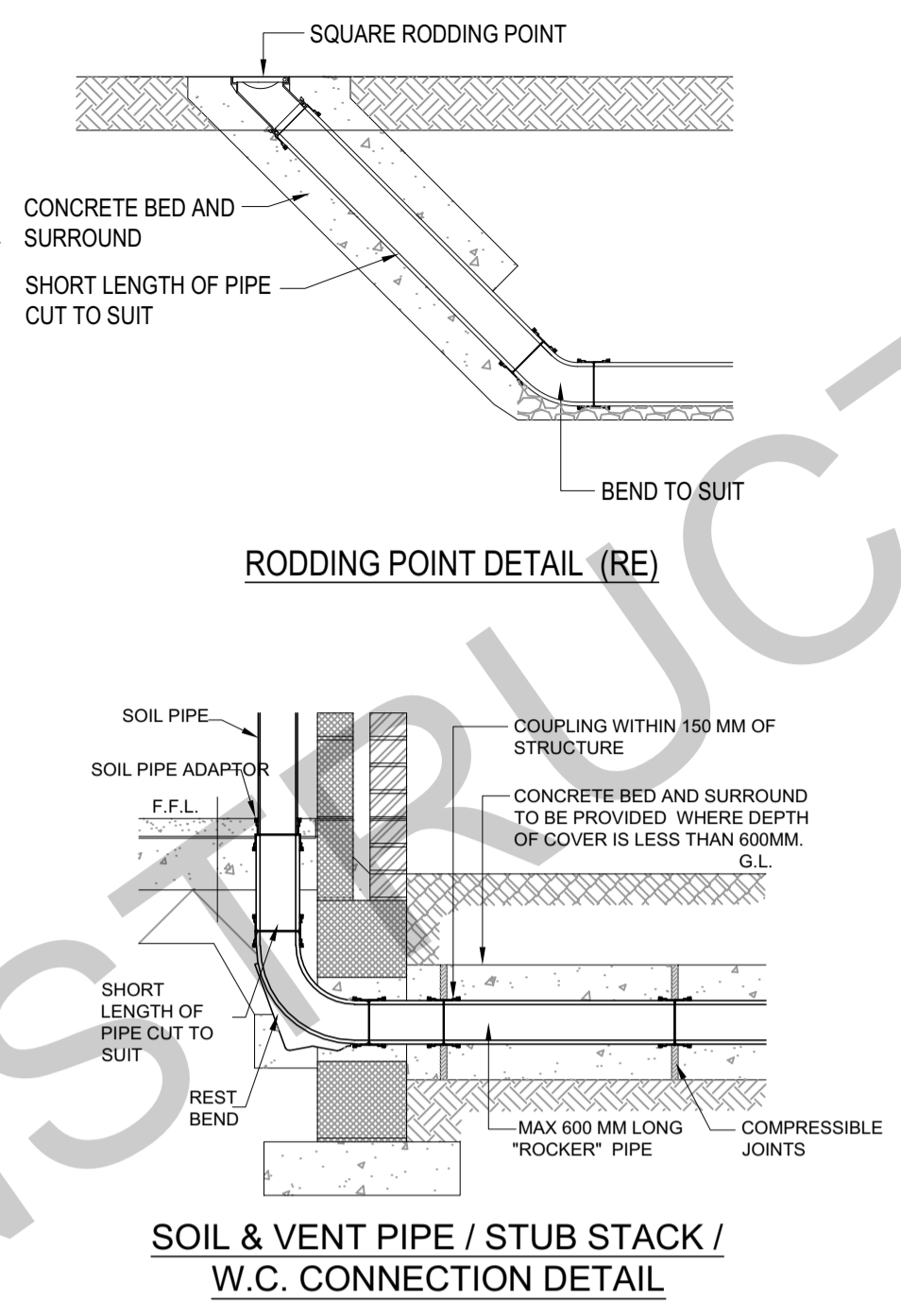
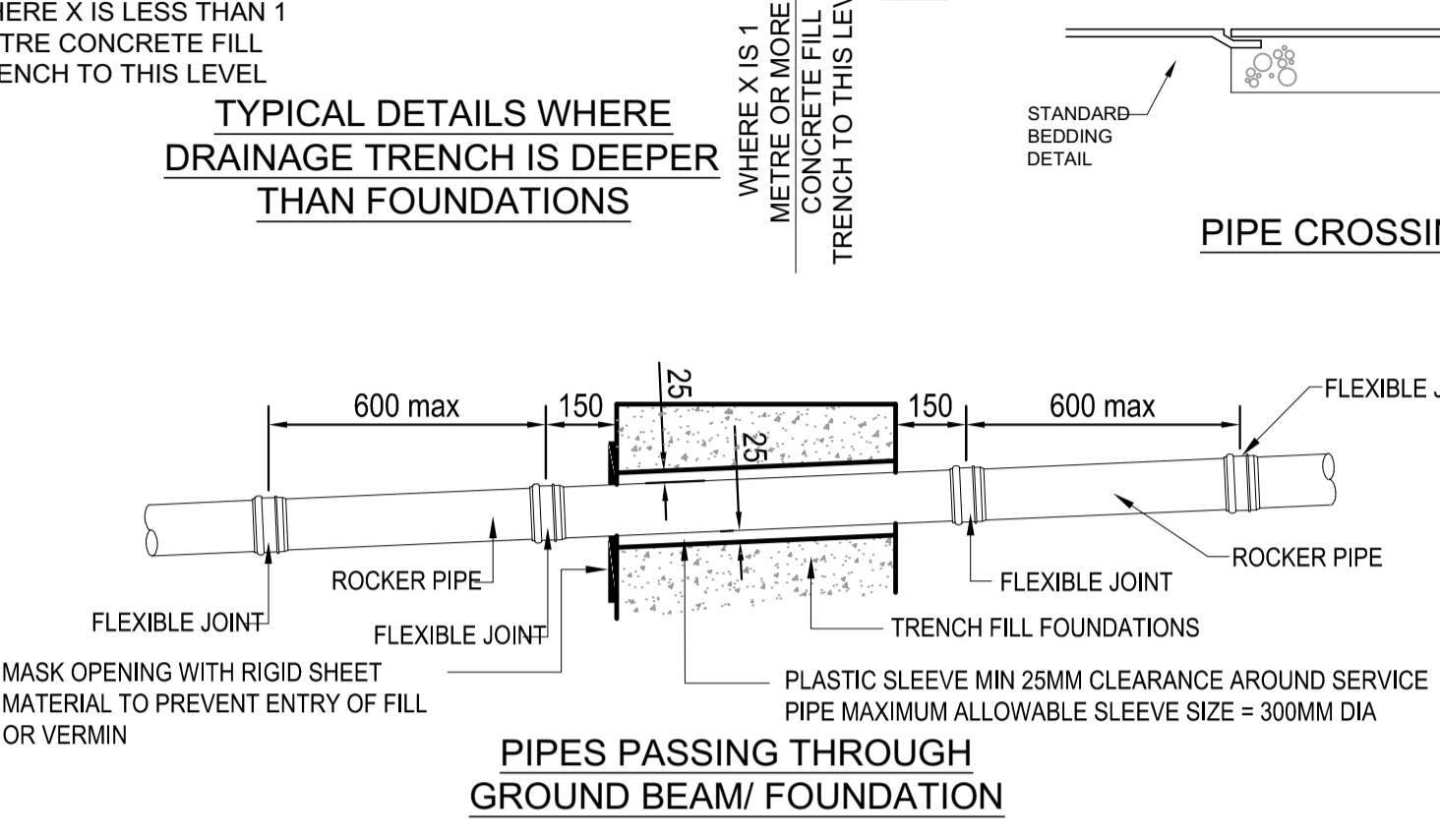
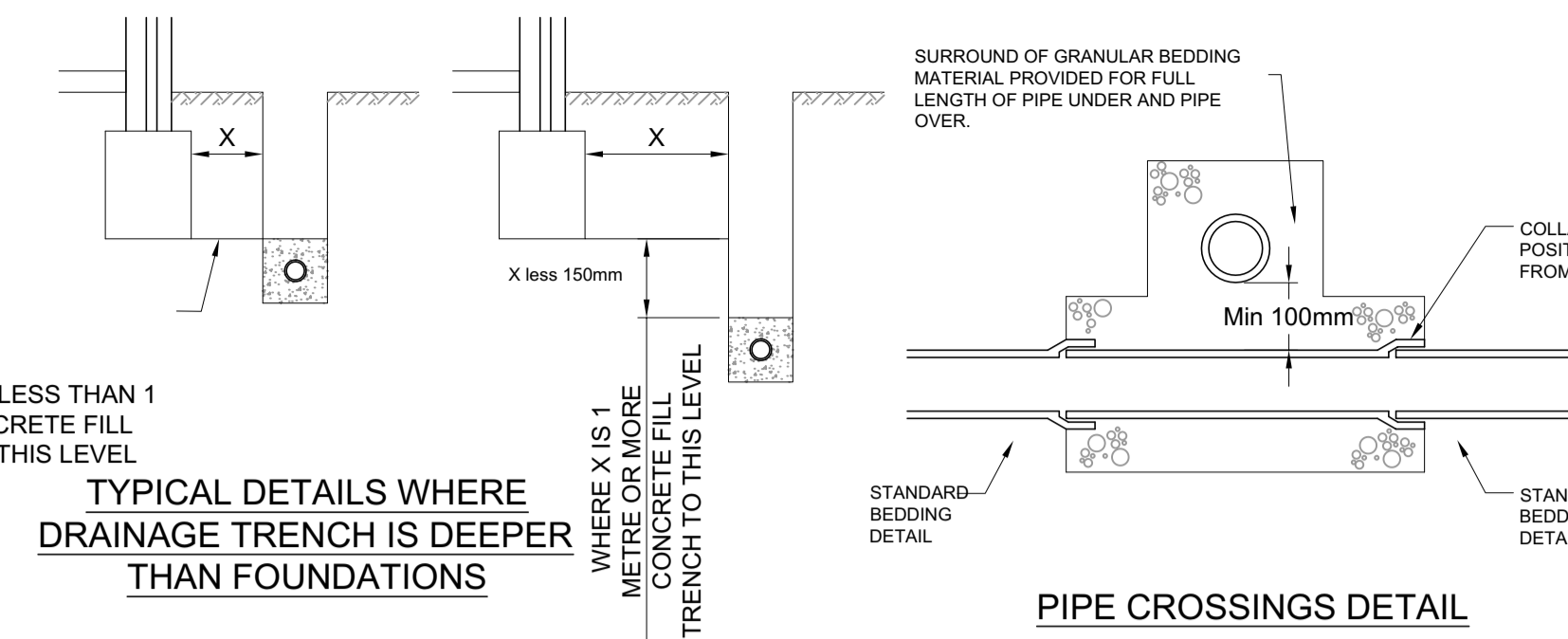
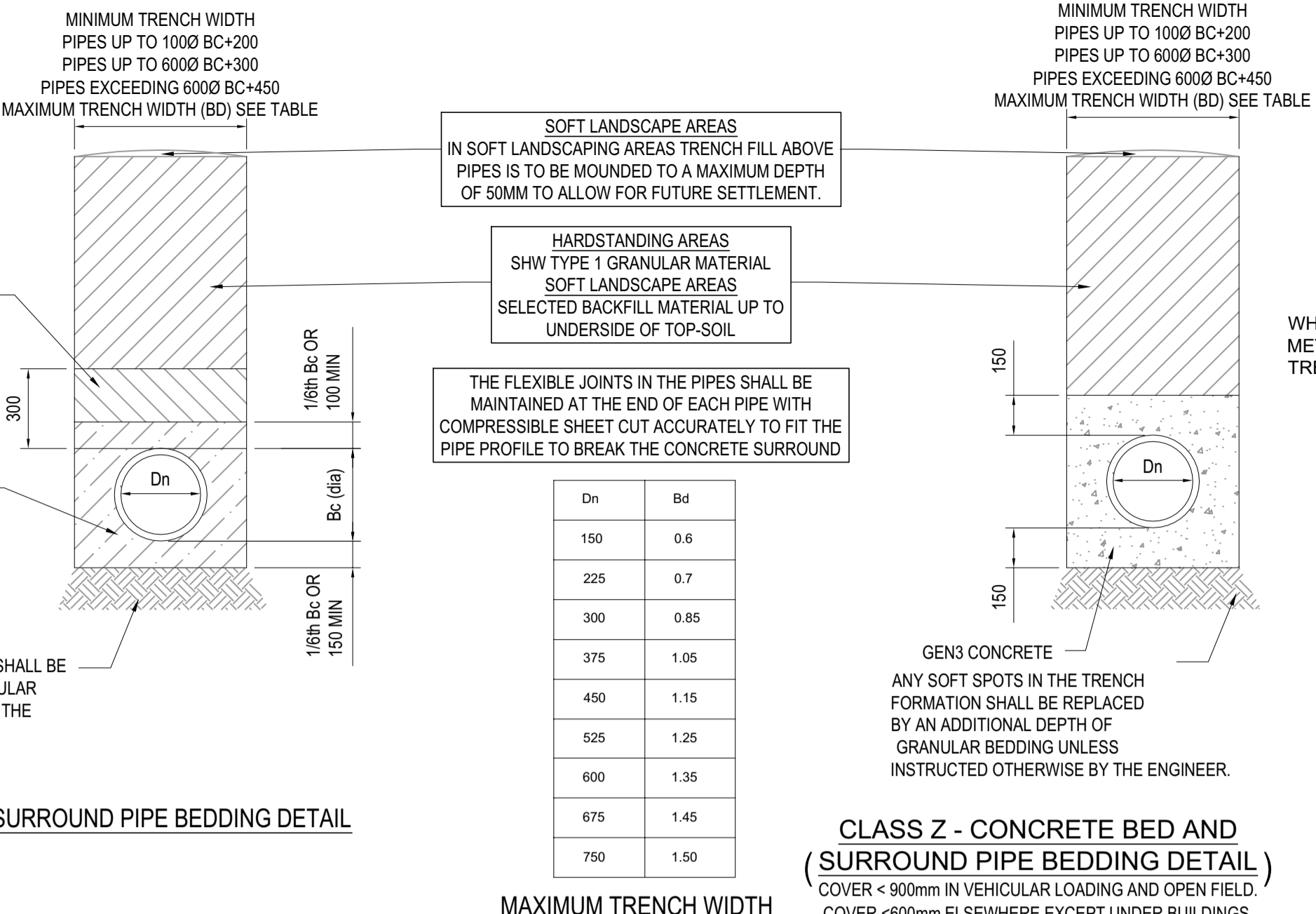

REV.	DESCRIPTION	DATE	DRW.	CHK.
C01	ISSUED FOR CONSTRUCTION	25.05.22	EBR	MW
P05	UPDATED IN LINE WITH MCC COMMENTS	16.02.22	ATL	MW
P04	STAGE 4 UPDATED	31.01.22	TH	ATL
P03	STAGE 4 ISSUE	17.12.21	ATL	CG
P02	DRAFT STAGE 4 ISSUE	28.08.21	MW	DS

**NHS**  
Manchester University  
NHS Foundation Trust

**ecurtins**  
Manchester Exchange, 17-19 Withworth Street West, Manchester M1 5WG  
0161 236 2364  
manchester@ecurtins.com  
www.ecurtins.com

PROJECT		NMGH MSCP	
TITLE		Drainage Details sheet 2	
STATUS	PURPOSE OF ISSUE		
S4	FOR CONSTRUCTION		
DRAWN BY	CHECKED BY	DATE	
MW	DS	28/06/2021	
SCALE (@A1)	PROJECT NUMBER		
1:20	075805		
FILE DRAWING NUMBER	REV.		
20200-CUR-NM110-ZZ-DR-C-9252	C01		